

CUBIX 48

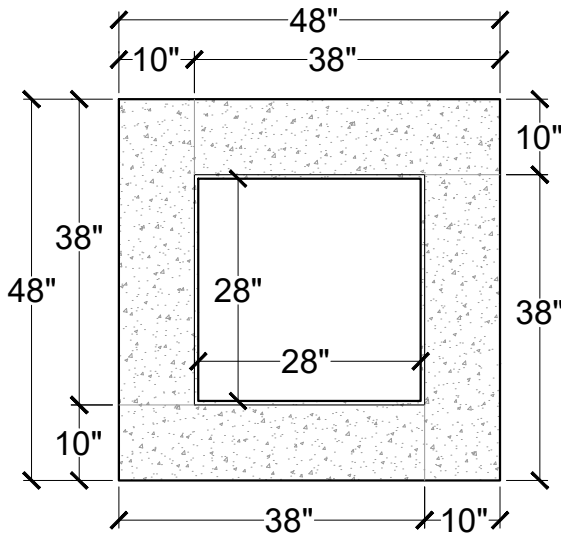

TOP VIEW

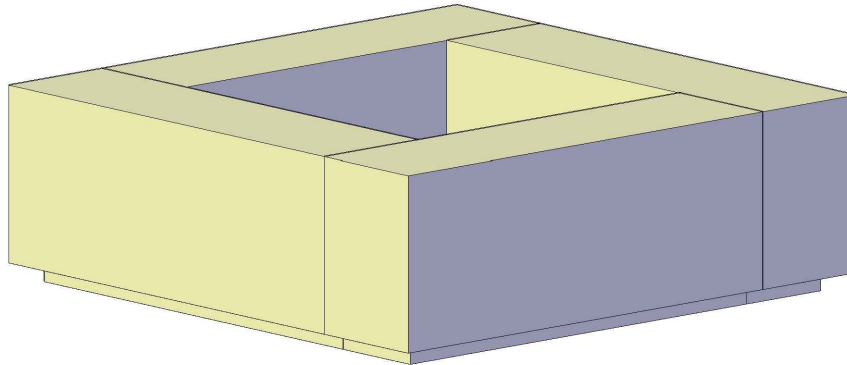
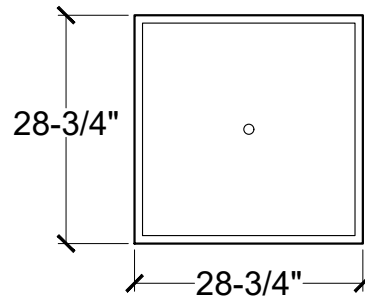

PAN SS 28-3/4"

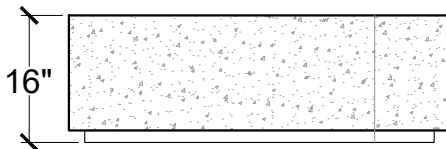

SIDE VIEW

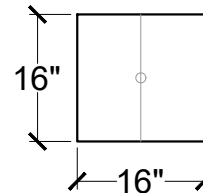

BURNER SS 16\"/>

* 70 LBS GLASS

* NO BLOCK REQUIRED

ONLY USE LAVA ROCK OR FIRE GLASS

GAS VALVE INCLUDED
INSTALL ON 4" SLAB

SS PAN, BURNER, FLEX HOSE, FIREGLASS SOLD SEPARATELY

Product	Description	Weight
CUBIX - 48	4 PCS 48" SQ. x 16" HEIGHT	480